



# GibbsCAM GO 5-Axis

Add-on Modules for 5-Axis  
Milling, MultiBlade, and Porting





## GO 5-Axis Milling

GibbsCAM's modular suite of CNC programming tools offers powerful solutions when you need to move beyond 3-axis milling into rotary milling of any type. GibbsCAM 5-Axis Milling, 5-Axis MultiBlade, and 5-Axis Porting options can accommodate your requirements with speed and efficiency.

Each GibbsCAM module has a different range of capabilities, different input requirements, and different toolpath capabilities. Selecting the best options for a specific part and machine will yield the best results. All of GibbsCAM's rotary milling options are supported by a huge library of post processors and a staff dedicated to building and maintaining post processors.

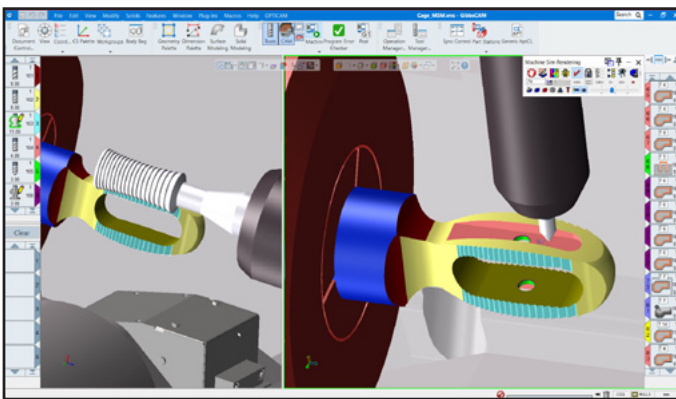

5-axis of medical cage

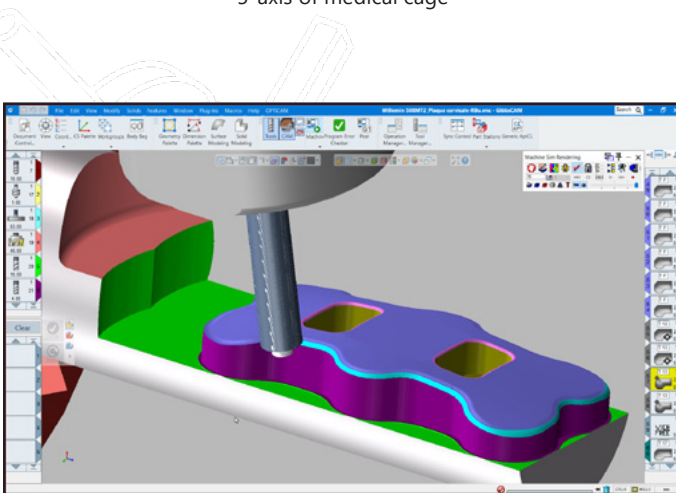

5-axis filleting of backbone plate

### 5-Axis Milling

GibbsCAM 5-Axis Milling module achieves 5-axis motion with 2 rotary and 3 linear axes. It provides powerful programming tools to meet all the challenges of 3-, 4- and 5-axis simultaneous machining, without sacrificing ease of use.

- Input is a combination of 3D wireframe geometry, solids and surfaces. GibbsCAM's geometry creation and editing tools accommodate any modeling or editing required to prepare a part model for machining.
- A robust set of multi-surface strategies supports machining a full range of uniquely shaped parts directly from the model's surfaces. The user has full control of tool axis tilt.
- Comprehensive collision control checks the tool and holder for collisions with the part and workholding devices, and automatically corrects the toolpath according to user specified parameters.

A sophisticated and powerful programming tool for any 5-axis programmer, this option is ideal for 5-axis simultaneous capable mills, mill-turns and MTM machines, and also a very good solution for 4-axis machines when working directly from solids and surfaces.

Automatic deburring creates toolpaths on the outer edges of a part's geometry. This process can dramatically increase productivity and quality, eliminating much manual work.

The integration of 5-Axis Milling with GibbsCAM MTM options supports the most advanced multi-task machines with live tooling on articulated heads. With its breadth of capability and ease of use, GibbsCAM 5-Axis Milling simplifies 5-axis programming and improves machining efficiency with better surface finish and faster throughput.

## 5-Axis MultiBlade

GibbsCAM 5-Axis MultiBlade module is optimized for programming machining centers and multi-tasking machines (MTMs) to make turbomachinery blade parts such as blisks, blings and impellers. The specialized and condensed interface allows easy selection of geometry without having to prepare the model.

Toolpath strategies include 5-axis simultaneous roughing, hub finishing, and blade and splitter finishing, with automatic gouge checking on all toolpaths. The interface offers intelligent controls for rotating toolpaths around the part as well as fillet machining, and all toolpath strategies.

- Roughing between blades with single splitter support
- Blade, splitter and hub finishing
- Leading- and trailing-edge extension and all toolpath strategies including edge roll trimming
- Toolpath segment rotations and sorting
- Tool axis tilt controls
- Tool axis smoothing
- Automatic axis detection
- Automatic and user definable links and clearances
- Stock definition for rest machining

5-Axis MultiBlade can program machining of parts that have single or multiple splitters and/or sub-splitters.

- Blade fillet finishing
- Splitter smoothing
- Multiple splitter support

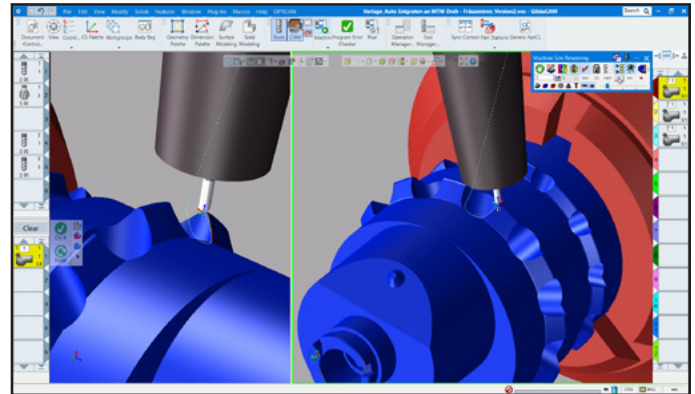

5-axis deburring

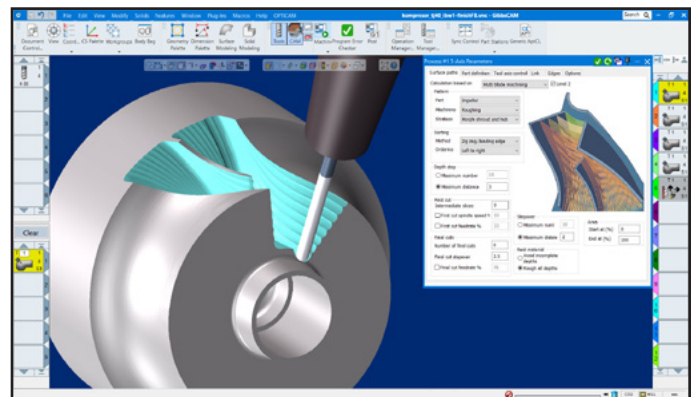

5-axis with roughing of multiblade

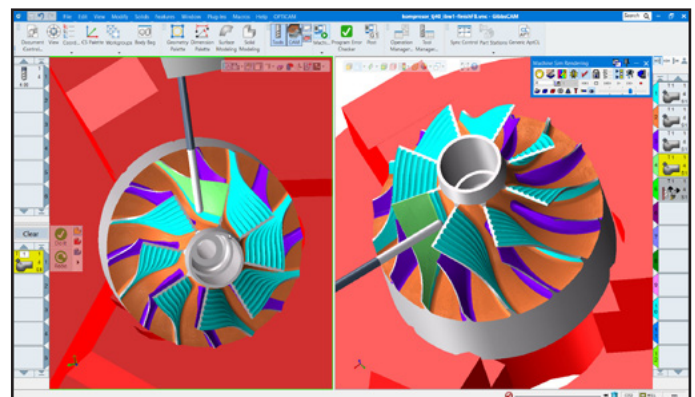

5-axis finishing of multiblade

## 5-Axis Porting

GibbsCAM 5-Axis Porting module optimizes machining for engine manifolds, throttle bodies, and any parts with tubular openings (or ports) that change shape and curvature from one end to the other. The software can automatically detect the spine curve through the port and align the toolpath accordingly.

Using available tool reach, it can split upper and lower operations automatically by maximum tool reach, midpoint, or user selected percent of reach, and ensures proper toolpath blending between upper and lower sections. Tool tilting is automatic, and all 5-axis motion is calculated to provide smooth and gouge free toolpaths.

With its condensed and specialized interface, the 5-Axis Porting option makes programming easier and faster, generating a cleaner, more efficient toolpath for faster and higher quality machining.

- Roughing and rest roughing strategies
- Spiral and plunge (along) finishing
- Automatic spine detection
- Automatically calculates optimal tilt angles without need to split surfaces or create tool axis control splines
- Cut only top of port, only bottom, or both sides, in single operation

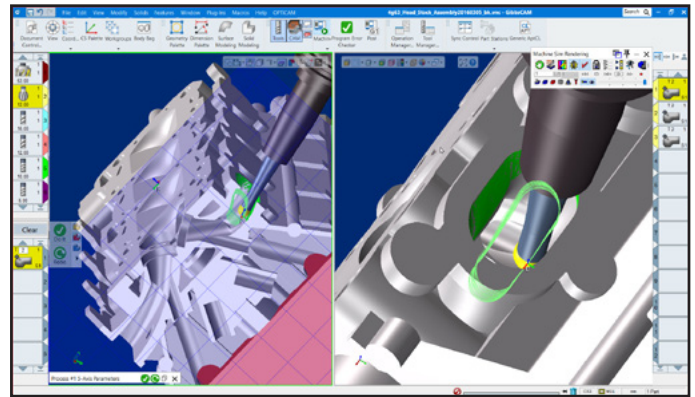

5-axis porting

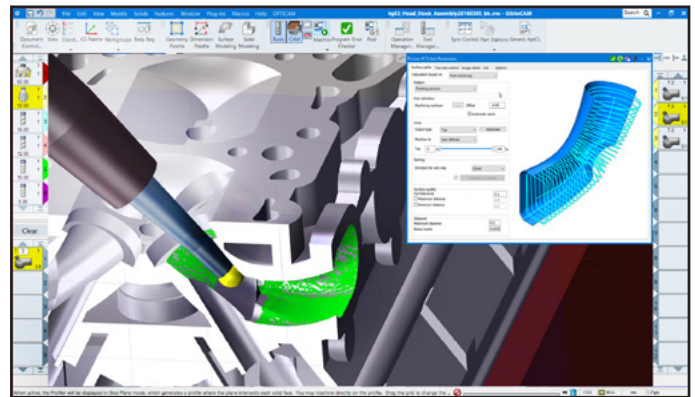

5-axis porting with dialog box



**Download latest version:**  
[www.gibbscam.com/downloads](http://www.gibbscam.com/downloads)



**Contact your dealer:**  
[www.gibbscam.com/reseller-finder](http://www.gibbscam.com/reseller-finder)



**Request Free 30-day trial:**  
[www.gibbscam.com/explore-gibbscam](http://www.gibbscam.com/explore-gibbscam)



## Other Add-On Options

As your shop grows, or replaces machinery, GibbsCAM helps you grow. Multiple options integrate with the same familiar, intuitive interface allowing you to program any part for efficient machining on any machine.

- Wire EDM for 2- to 4-axis
- Tombstone Management Systems (TMS)
- On Machine Probing