



GibbsCAM GO Milling

Simply Powerful CAM Packages
That Match Your Operations



GO

with GibbsCAM GO Milling

GibbsCAM GO Milling offers simply powerful CAD/CAM software at the level that matches your business. Choose the right milling, turning, or combination package that matches your production needs today. Level up to a higher capability solution at any time to take advantage of greater feature set.

GO Milling

2.5-Axis and Simple
3-Axis with
Wireframe Milling



GO Solid Milling

2.5-Axis and 5-Axis
Positional with
Powerful Solid
Modeling



GO Pro Milling

3-Axis and 5-Axis
Positional with
Powerful 3D
Modeling



GO Mill/Turn

Choose Your
Combination of
GO Milling and
GO Turning Levels





GO

GO Milling

An easy-to-use
CNC programming
solution for shops
that are cutting
2.5-axis features
such as pockets,
holes, and slots



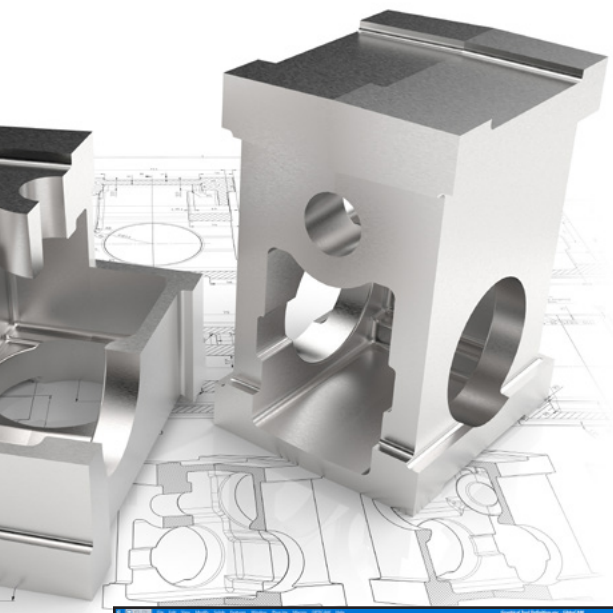

GO Milling

GibbsCAM GO Milling provides powerful yet easy-to-use programming capabilities for 2-axis through simple 3-axis wireframe machining. GibbsCAM creates CAD for manufacturing to accelerate the programming process.

Contouring, pocketing, thread and face milling, spiral creation, drilling, tapping, and boring are standard CNC with GibbsCAM GO Milling. Walls can be tapered or straight, or can even follow a swept shape. Finish your parts with automated face milling from spiral, zig-zag, back-forth, and one direction.

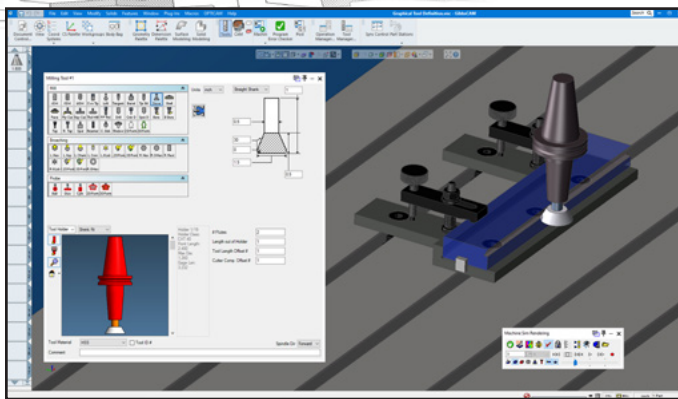

Graphical tool definition displays tool types and key dimensions

Freeform Geometry Creation

Whether you start with imported geometry or need to create your own geometry, the GibbsCAM GO Milling freeform geometry capabilities provide a powerful means to create and edit geometry for machining. The GibbsCAM graphical user interface infers what operations you want to perform based on the selected elements, which dramatically streamlines interactions with the system. Chaining is not required so there is no need to stop the workflow continually to trim and connect geometry.

Graphical Tool Definition

The GibbsCAM GO Milling graphical user interface displays key dimensions to create error-free tools easily. It supports a wide variety of predefined tool types and user-defined form tools.

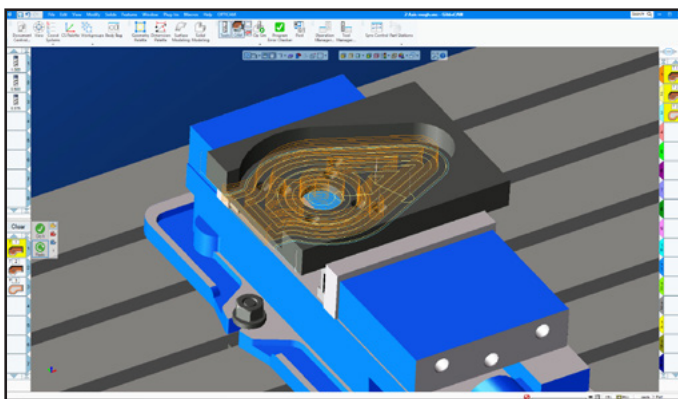

Multi-process programming

Multi-Process Programming

Select geometry once and apply multiple machining operations like a series of rough, semi-rough, finish passes to it all at once. The resulting processes are associated with each other and the original geometry, so updates are accommodated easily.

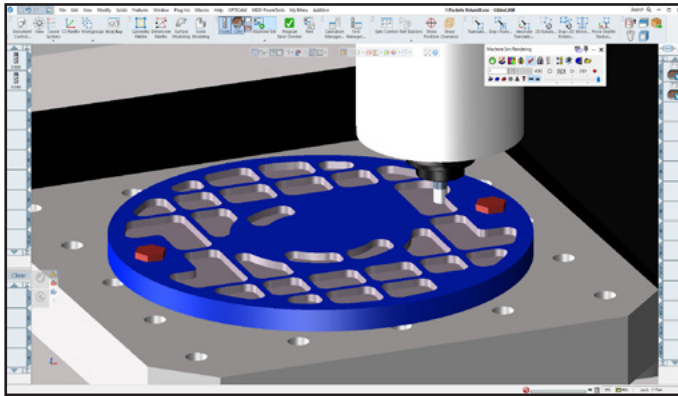

Toolpath visualization and verification

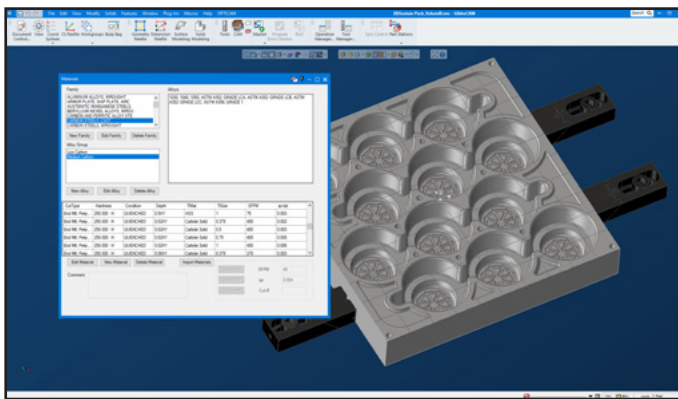

CutDATA recommends feeds and speeds

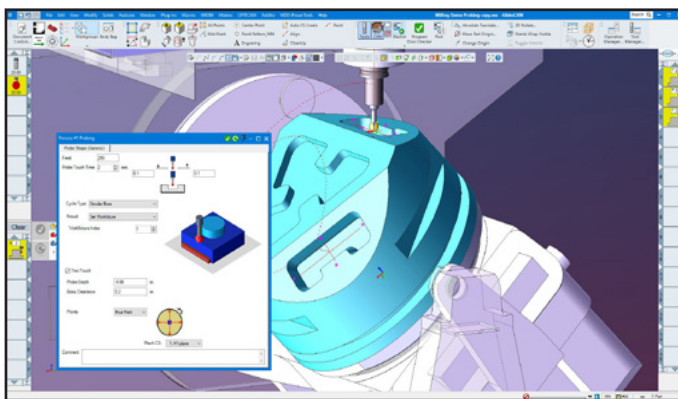

Probing (optional add-on)

Hole-Making Sub-Routines

GibbsCAM GO Milling supports a wide range of boring (bore, fine bore, backbore), drilling, and tapping sub-routines to optimize efficient hole-making operations. You can also program thread mills, and support for rotary and linear broaching is built in.

Toolpath Visualization and Verification

3D rendering of the toolpath, showing cutting action and an accurate preview of machining and surface finish.

CutDATA™

Over 71,000 machining recommendations for feeds and speeds for use with Material Database. CutDATA is user-configurable to create a speeds and feeds database suited to how you machine your parts.

Advanced Coordinate Systems

GibbsCAM GO Milling offers multiple coordinate systems for modeling, and 4 and 5-axis rotary positioning.

Utility Operations (Non-cutting Motions)

Program non-standard axes [e.g. a quill or W-axis], or program machine attachments like a robot, pallet changer, steady rest, or tailstock.

Probing (Optional Add-on)

GibbsCAM Probing lets you program setup and in-process inspection for a wide variety of machines, and supports probing technologies from all major inspection vendors. Users are able to specify a measurement cycle as G-Code to be inserted into the program at selected probing points. Probing automatically handles the positioning and orientation of the probe, including safe traversals between probe points.



GO

GO Solid Milling

Add the power & productivity of creating, editing, and machining solid models to your GO Milling package



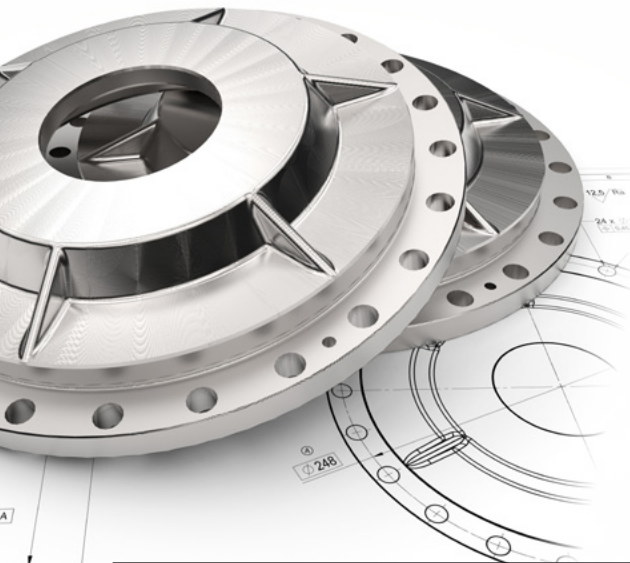

GO Solid Milling

GibbsCAM's cost-effective suite of solids-based options provide a more complete representation and enable more intuitive modeling and advanced machining capabilities for today's solid and surface models.

Create ultra-efficient part programs with gouge-free toolpaths using GibbsCAM's integrated advanced machining capabilities. Programming efficiency is significantly enhanced with highly automated multi-tool, multi-surface roughing and finishing, and "material only" machining methods.

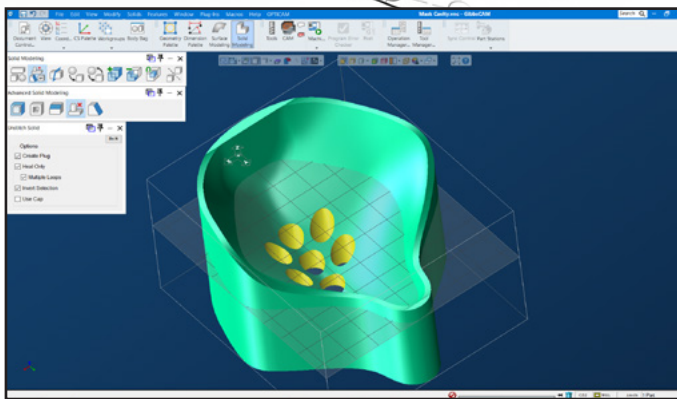

Powerful solid modeling

Powerful Solid Modeling

Whether you import solid models from a CAD system, create your own from scratch, or modify an imported solid to create a manufacturable version, GibbsCAM GO Solid Milling provides a full range of solid modeling functionality with advanced functionality like history trees to support you. And its industry-leading ease-of-use makes working with solids straightforward and easy-to-understand. With its powerful solid modeling tools, you can take full advantage of solid modeling technology.

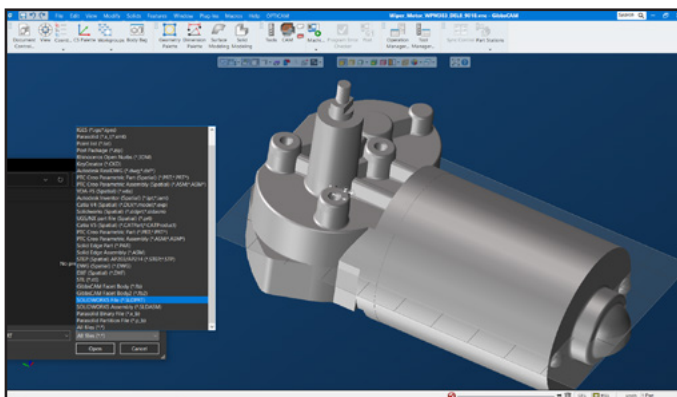

Importing and repairing models

Importing and Repairing Surface Models

Even with the transition to solids, CAD systems still generate surface models that must be imported and machined. With GibbsCAM GO Solid Milling, you can read in surface models and then repair any problems that you encounter with a broad range of surface modeling tools. And you can create your own surfaces for machining. If you still work with surface models, GibbsCAM GO Solid Milling can still cut your jobs and provide a great migration path to solids-based machining.

CAD Import

Import Parasolids, ACIS/SAT, STEP® and VDA models, and also directly from well-known CAD systems such as Solid Edge®, SOLIDWORKS®, and Inventor®. Options are available to extend CAD Interoperability for PTC, CATIA and NX.

Automatic Solidification

With GibbsCAM GO Solid Milling, you do not have to start with solid models to take advantage of solids-based machining. Automatically stitch surface models together, whether imported or created, to create solid models that can then be further modified with the GibbsCAM solid modeling tools or machined directly.

Solids Positioning Tools

Powerful positioning tools allow you to position and orient solids easily and precisely, and avoid the hassle of calculating transformation to orient them correctly. Not only are these tools extremely useful when modeling a single part made up of multiple pieces, but they can streamline setting up part models in fixturing significantly.

Directly Machining 2.5D Solids

Not only do solid models provide considerable advantages during design, but they also offer many advantages during machining. GibbsCAM allows users to machine solids directly and take advantage of the additional information available in solids, which results in improved performance, reliability, and efficiency.

Profiler

Identifying the manufacturable features in a part is a common starting point for a program. The Profiler interactively defines features like bosses, slots, and pockets. Unlike automatic feature recognition, the Profiler gives you complete control over the geometric elements that are included in a feature. The Profiler can also derive geometry interactively with feature-based machining.

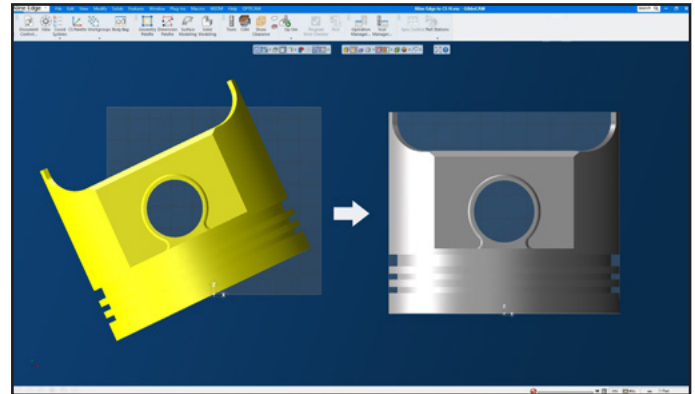

Align edge to coordinate system for easy orientation

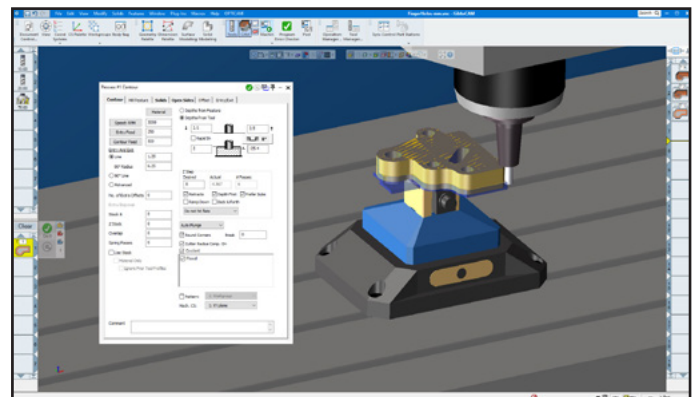

Directly machining 2.5D solids

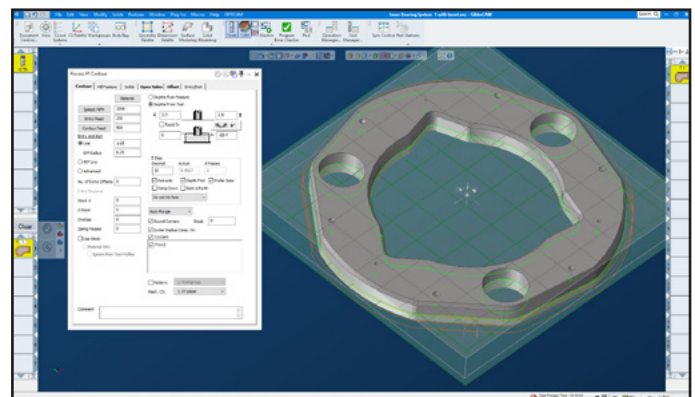

Interactive Profiler controls geometric elements

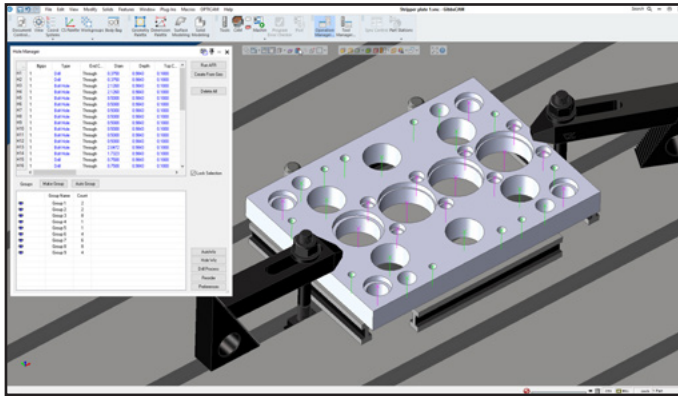

Automatic feature recognition / hole manager

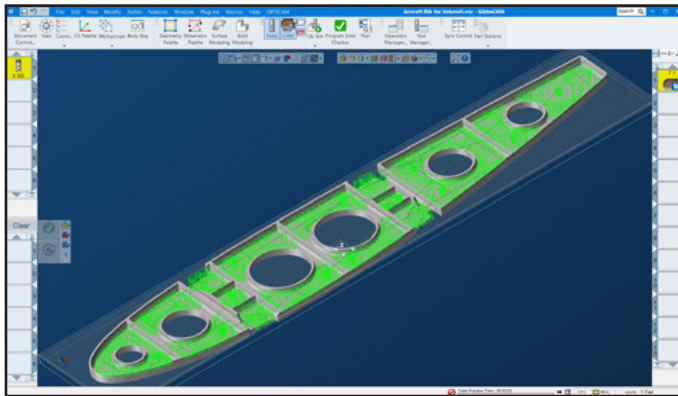

VoluMill adds powerful high-speed material removal

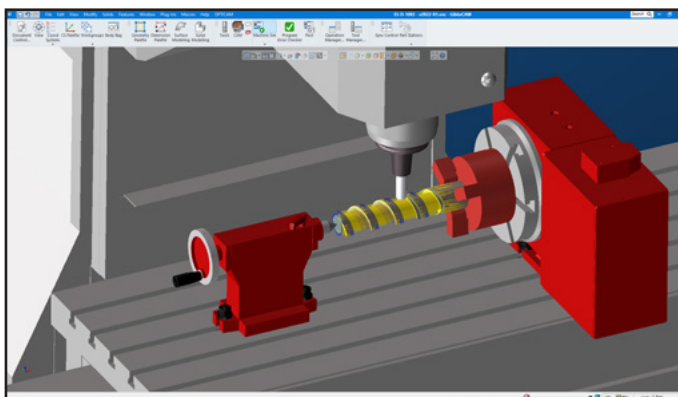

Radial milling

Automatic Feature Recognition

Hole-making represents a significant amount of programming and machining time. GibbsCAM GO Solid Milling provides an automatic feature recognition (AFR) capability that identifies holes along with their position and orientation and also determines various hole aspects (chamfer, counter-sink/bore, bottom condition) based on the hole's geometry.

Hole Manager

The Hole Manager streamlines the time-intensive process of hole-making by identifying hole parameters and grouping them for processing. The Hole AFR is integrated with the Hole Manager so that you can identify hole features to be loaded automatically. The Hole Wizard is similarly integrated so that hole information is passed directly for automatic tooling and toolpath generation.

Machine Simulation

Identify any programming errors before they cause costly mistakes on the shop floor. Uses a model of your machine tool to simulate machine tool motion and verify your setup.

VoluMill™ Solids

Adds powerful high speed roughing functionality and controlled material removal rate for machining solid models. Automatically avoid tool and holder collisions in deep pockets. Wall cleanup functionality leaves minimal material on tapered walls without wasting machining time.

Radial Milling

Simultaneously drives one rotary axis (A, B, or C) with X, Y, and/or Z for true 4-axis analytic cutting. Supports Y-axis off-center milling for radial prismatic parts defined by solid models or 3D geometry.



GO

GO Pro Milling

Add the power of 3-axis solid and surface part modelling to your GO Milling package. Create, repair, modify, machine in 3D. Automate super smooth roughing and finishing cycles with gouge free toolpaths.



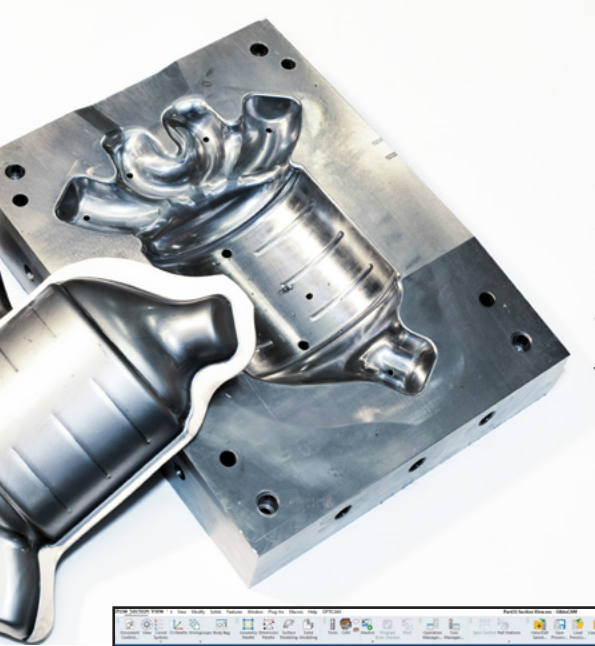

GO Pro Milling

GibbsCAM GO Pro Milling is designed to handle the most exacting of modeling and machining demands for complex mold, tool, and die creation. GibbsCAM GO Pro Milling includes high-level modeling and advanced functionality for machining surfaces and solids.

Tackle complex functions easily with the intuitive GibbsCAM user interface. Use the advanced 3D high-speed machining in GibbsCAM GO Pro Milling to create a toolpath that is ideal for hard metal cutting and for smooth surface finishes.

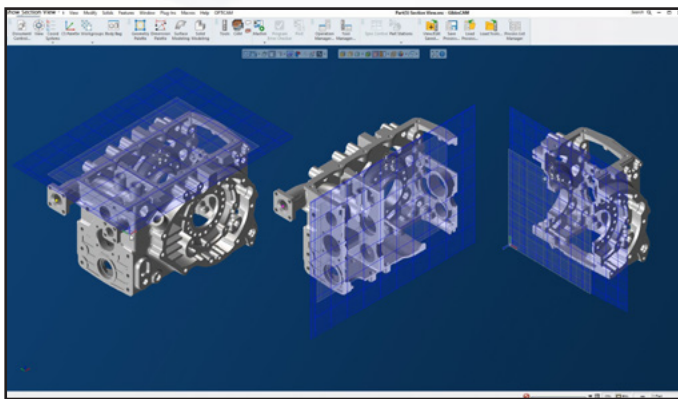

Section view reveals internal X, Y, Z views on cavity

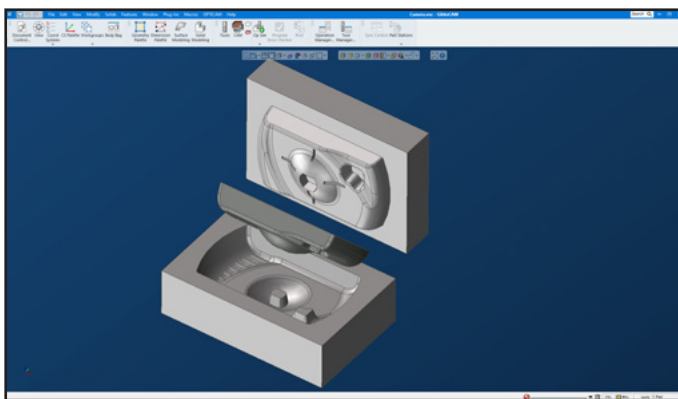

Extract/Heal capability for core and electrode creation

Extended Surface Modeling Capabilities

Though parts files are often provided in solid model format, surface modeling is a key capability for programmers. GibbsCAM GO Pro Milling provides extended surface modeling capabilities to handle surface creation or modification. And its powerful surface modeling functionality is easy to use.

Automatic Parting Line Generation

You need to separate mold halves at the extents of the part to ensure that the part can be removed readily. Manually determining where the parting line should be is a very tedious process. With GibbsCAM GO Pro Milling, you can generate the correct parting line automatically and then use it to divide the mold halves easily.

Extract/Heal Features (for Core/Cavity or Electrodes)

Often parts include minor features that get in the way when generating toolpaths. You can suppress these features with the GibbsCAM GO Pro Milling extract/heal feature capability, which removes the feature's geometry and heals the surrounding area. You can use the solid, which is generated from the suppressed feature, to create cores or electrodes.

Multiple Offsets

You must consider different types of surfaces when machining: the surface that is being machined, the part surfaces not being machined, and any surfaces associated with fixtures. With GibbsCAM GO Pro Milling, you can specify the offset, or how closely the tool comes, for each of these surface types. So, you're in complete control when generating toolpaths.

3D Projection Machining

Sometimes you want to have direct control of the toolpath over multiple surfaces. You generate the toolpath you want and then you project it onto the surfaces to be machined. The source for the toolpath geometry can be just about anything, including text. GibbsCAM GO Pro Milling provides a powerful capability that allows you to project geometry onto surfaces to generate final toolpath geometry.

Advanced 3D with High-Speed Machining

Advanced 3D with High-Speed Machining (HSM) adds the next level of 3D surface and solid body machining:

- New types of finishing processes
- Support for 3D material only toolpaths
- Enhanced entry/exit control
- Direct machining for faceted bodies such as imported STL files
- Automatic core/cavity detection for inside-out or outside-in determination
- Operation splitting for tool wear and for optimal length out of the holder
- Automatic filleting of a surface to avoid sharp concave corners
- Support for batch toolpath generation

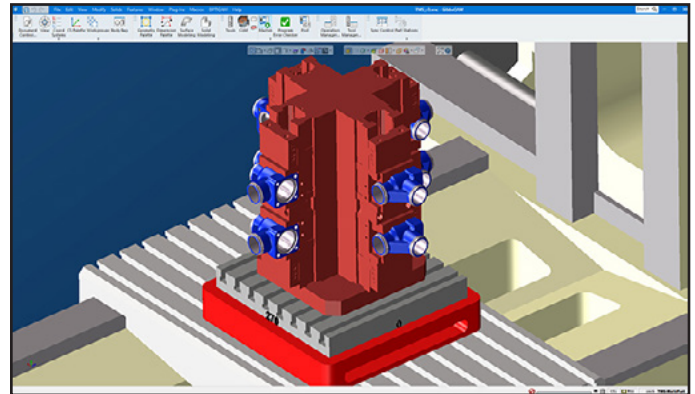

Tombstone (optional add-on)

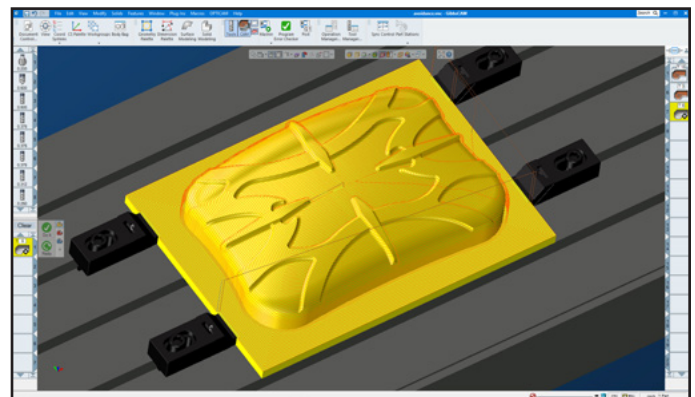

3D machining

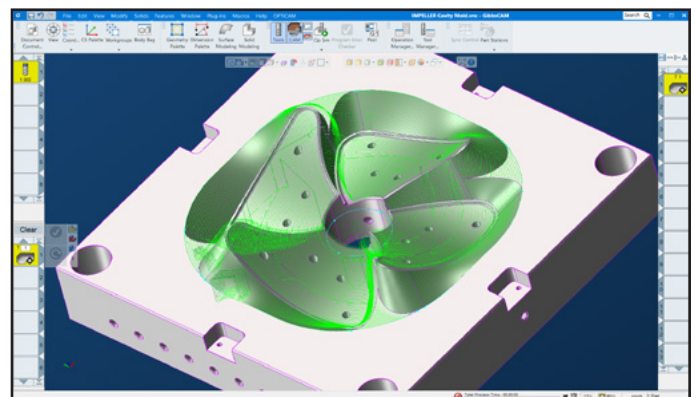

3D machining

GO

GO Mill/Turn

Choose Your
Combination of
GO Milling and
GO Turning Levels



GO Mill/Turn

By combining GO Milling and GO Turning, you gain mill/turn capability, with support for X, Y, Z linear axes plus a C or B rotary axis. Fast parametric radial duplication of repetitive operations and of features such as holes, slots, pockets and flats makes quick work of complex mill-turn parts. GO Mill/Turn also supports simultaneous turning on the B-axis.

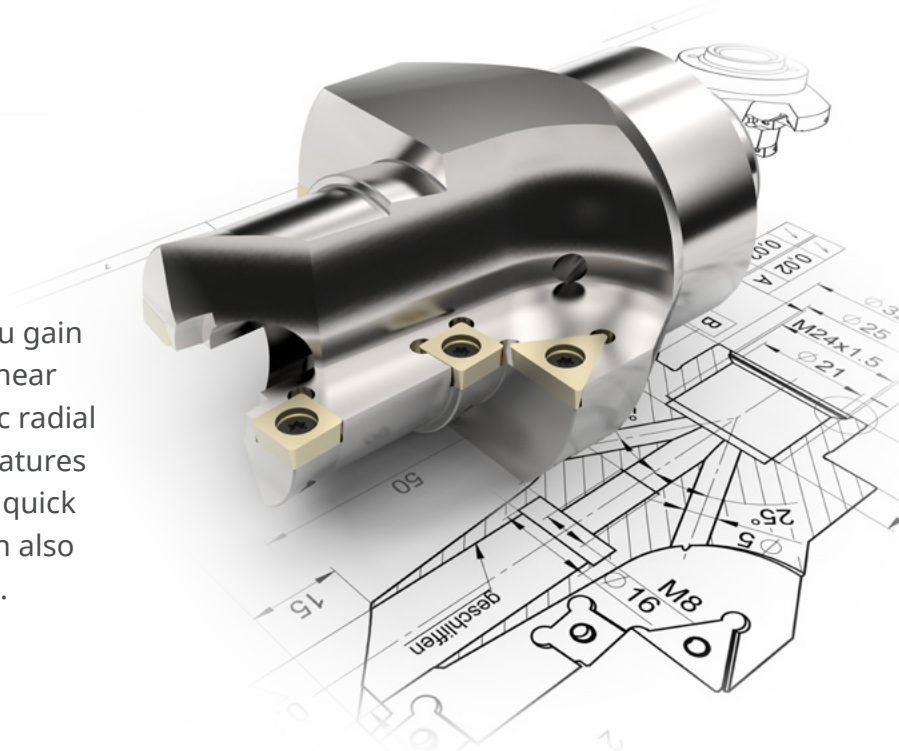

GO Milling

2.5-Axis and Simple 3-Axis
with Wireframe Milling

GO Turning

2-Axis Fulling Functional
Wireframe Machining

GO Solid Milling

2.5-Axis and 5-Axis
Positional with Powerful
Solid Modeling

GO Solid Turning

2-Axis Turning with
Powerful Solid Modeling
and Simulation

GO Pro Milling

3-Axis and 5-Axis
Positional with Powerful
3D Modeling

Extend your Capabilities

As your shop grows, or replaces machinery, GibbsCAM helps you grow. Multiple options integrate with the same familiar, intuitive interface allowing you to program any part for efficient machining on any machine.

- 5-Axis Simultaneous Milling
- Multi-Blade and Porting
- Multi-Task Machining (MTM), including Swiss Machining
- Tombstone Management Systems (TMS)
- Wire EDM for 2D to 4-Axis
- On-Machine Probing

GO

GibbsCAM GO Milling Packages



GO Milling

- Freeform Geometry Creation
- Graphical Tool Definition
- Multi-Process Programming
- Polar and Cylindrical Milling
- Advanced Pocketing Routines with VoluMill™
- Hole-Making Sub-Routines
- Toolpath Visualization and Verification
- CutDATA™
- Advanced Coordinate Systems
- Utility Operations (Non-Cutting motions)



GO Solid Milling adds a next level to GO Milling

- Powerful Solid Modeling
- Importing and Repairing Surface Models
- CAD Import
- Automatic Solidification
- Directly Machining 2.5D Solids
- Solids Positioning Tools
- Profiler
- Automatic Feature Recognition
- Hole Manager
- Machine Simulation
- VoluMill™ Solids
- Radial Milling

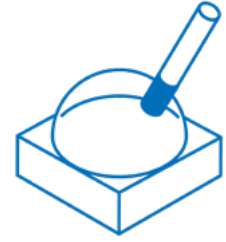

GO Pro Milling adds a top level to the complete set

- Extended Surface Modeling Capabilities
- Automatic Parting Line Generation
- Extract/Heal Features (for Core/Cavity or Electrodes)
- Multiple Offsets
- 3D Projection Machining
- Advanced 3D with High-Speed Machining

GO Mill/Turn Combination Packages

Combine the GO Turning and GO Milling packages that work best for your operations.

Add-On Options

- 5-Axis Simultaneous Milling
- Multi-Blade and Porting
- Multi-Task Machining (MTM), including Swiss Machining
- Tombstone Management Systems (TMS)
- Wire EDM for 2D to 4-Axis
- On-Machine Probing



Download latest version:
www.gibbscam.com/downloads



Contact your dealer:
www.gibbscam.com/reseller-finder



Request Free 30-day trial:
www.gibbscam.com/explore-gibbscam

