



**GibbsCAM GO Swiss**  
Simply Powerful Swiss Machining



## GO Swiss Machining

GibbsCAM GO Swiss is the best tool to program complex, high precision parts on Swiss-style CNC machines. The simplicity of GibbsCAM within the comprehensive toolset takes the stress out of programming these specialized machines.

GibbsCAM's intuitive user interface provides seamless access to both turning and milling capabilities. You have the freedom to program using 2-axis turning to complex mill/turn with B-axis or Y-axis combined with 5-axis.

Full associativity ensures that machining operations are automatically updated when changes are made to the program. Factory-supplied post processors produce multi-flow NC code complete with utility operations and sync codes, maximizing your machine investment and reducing run times.

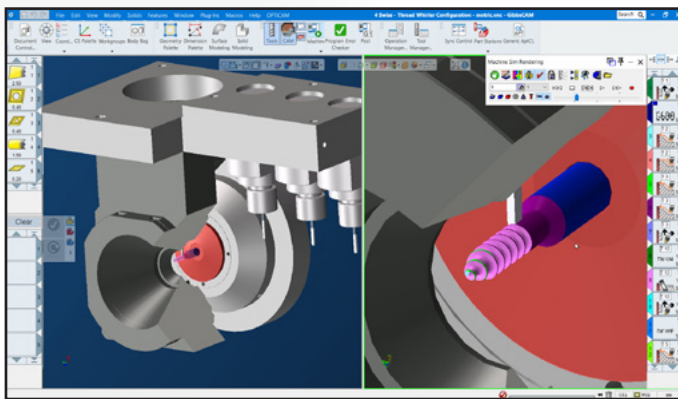

Machine-specific setup

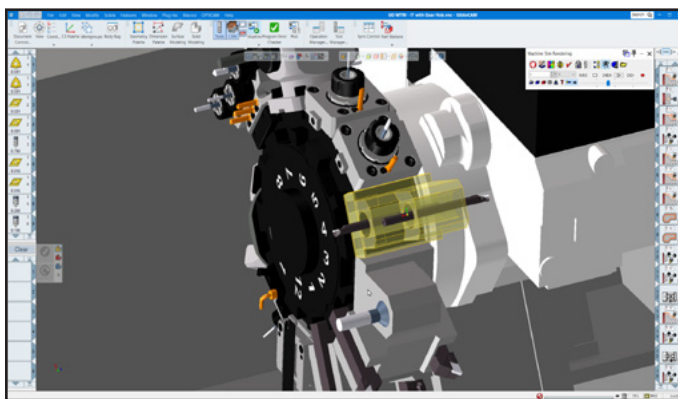

Intermediate tooling provides more accurate simulation of cutting motion

### Machine-Specific Setup

Swiss machine tools represent some of the most diverse and complex machine tool configurations available today. With GibbsCAM GO Swiss, your machine tool's specific configuration is captured by GibbsCAM's factory-supplied settings. You can be sure that you are accurately programming all your machine tool's capabilities and taking full advantage of maximum productivity. You can also quickly switch a machine from one set up to another, such as switching a thread whirling head with a tool post.

### Intermediate Tooling Support

Tooling is more manageable, simulation more accurate and programming easier, with more accurate tool placement and orientation. Fixed and live tooling is defined, located, and oriented on the machine tool using GibbsCAM's graphical interface.

- Support for tool blocks (adapter blocks, holders for tool holders, right-angle and adjustable heads and flash tooling) with tool block library
- Support for fixtures (chucks, tailstocks, steady rests and other work holding) including fixture library
- Simplifies programming through easy and accurate placement and orientation of tools

## Unlimited Tool Groups and Spindles

Today's Swiss machines incorporate a wide variety of multiple spindle and turret combinations, along with sliding headstocks, guide bushings and tool posts. GibbsCAM GO Swiss software enables users to program machines that have any number of turrets and spindles.

## Universal Kinematic Machine Technology

GibbsCAM Universal Kinematic Machine (UKM) technology allows users to program, simulate, and post process for machines with any number of axes and flows.

- Accurately simulate all the machine components and capabilities of any machine
- Generate complete, error-free post processed output that maximize your machine capabilities
- Scalable technology that is ready to support future machine solutions

## Sync/Flow Manager

GibbsCAM Sync Manager provides an easy to understand, intuitive, graphical interface allowing you to focus on optimizing your process. The Sync Manager handles all the underlying complexities for you.

- Displays multiple, parallel process flows including pinch turning and pinch turning (shown)
- Calculate operation times to optimize machine moves
- Control non-cutting machine moves
- Automatically check for invalid operations or synchronization

## Integrated Process Rendering

GibbsCAM MTM's integrated simulation allows you to fully verify your programs including multiple tools cutting at the same time, on-screen, reducing the risk of gouges and collisions.

- Visual gouge checking
- Check efficiency of cutting and non-cutting moves
- Simultaneously visualize multiple workflows

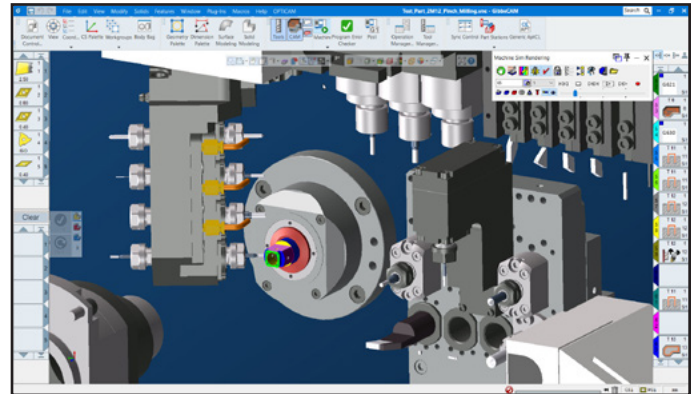

Program machines with any number of turrets and spindles

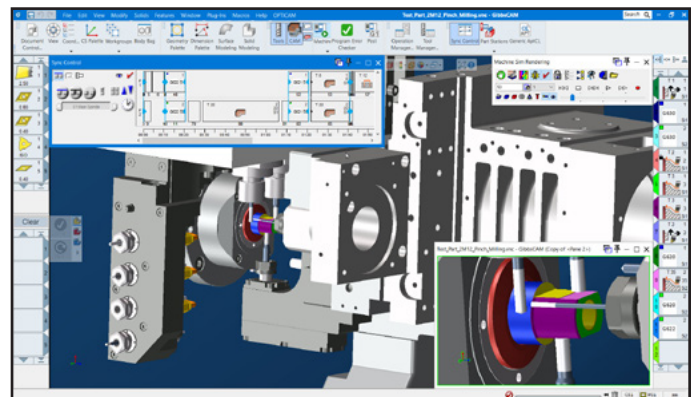

Easily visualize flows and machining processes with GibbsCAM Sync Manager

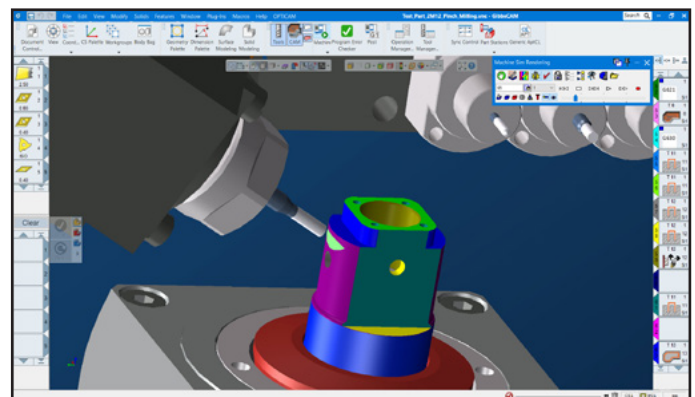

Integrated Process Rendering

## Utility Operation Support

GibbsCAM Swiss supports the entire range of utility operations used by your machine tool, providing full control all the way to posted output. Fully controlling non-cutting moves ensures that you fully utilize your MTM machine tool to maximize your return on investment.

- Re-chuck bar stock
- Sub-spindle part transfer
- Bar feeders and part catchers

## In-house Development of Post Processors

Our in-house team of expert post processor developers ensure that you get posted output specifically formatted for your machine tool that fully supports its capabilities. With factory-supplied posts, you do not spend your time figuring out how to post output for your machine tool - we take care of that for you.

## Machine Digital Twin Simulation

An extension to the GibbsCAM integrated Cut Part Rendering visualization/verification capability, Machine Simulation uses animated digital twin models to identify any program errors before they cause costly mistakes on the shop floor.

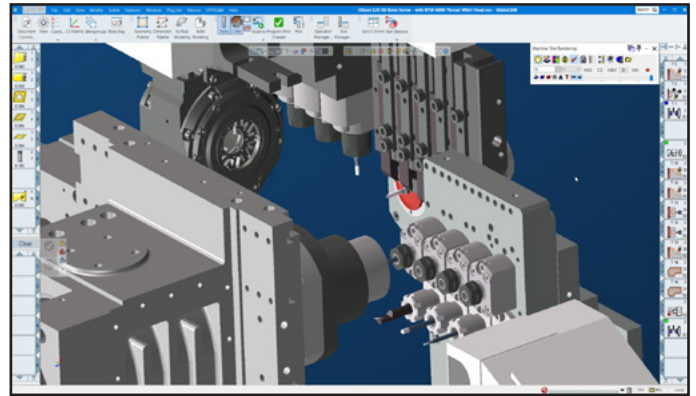

Program the most complex Swiss-style machines with the same easy-to-use GibbsCAM interface.

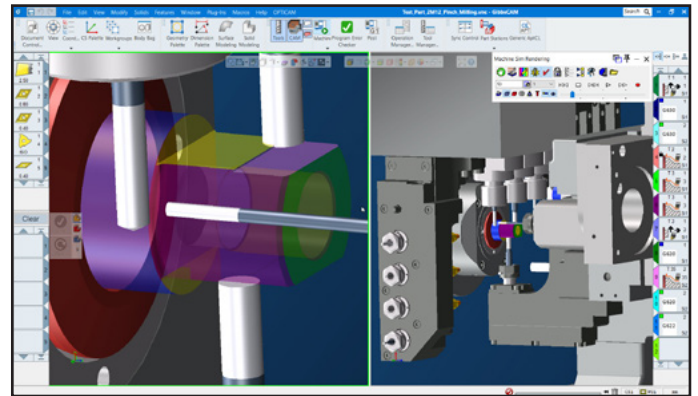

Fully verify NC programs on-screen, reducing the risk of gouges and collisions



Download latest version:

[www.gibbscam.com/downloads](http://www.gibbscam.com/downloads)



Contact your dealer:

[www.gibbscam.com/reseller-finder](http://www.gibbscam.com/reseller-finder)



Request Free 30-day trial:

[www.gibbscam.com/explore-gibbscam](http://www.gibbscam.com/explore-gibbscam)



## Add-On Options

As your shop grows, or replaces machinery, GibbsCAM helps you grow. Multiple options integrate with the same familiar, intuitive interface allowing you to program any part for efficient machining on any machine.

- 5-Axis Simultaneous Milling
- On-Machine Probing